

The National Construction Code sets out the minimum performance requirements for the construction of buildings in Australia and references over 100 other documents, including Australian Standards, ABCB protocols, ABCB standards and other publications, for technical, material or testing requirements, design and construction specifications.

Australian Standards, as with other types of referenced documents, are periodically revised to ensure they remain current and keep pace with new technologies, so it can be confusing to determine which revision of a referenced document to use, especially when they may be updated between NCC cycles.

NCC Governing Requirements - Part A4

Part A of the NCC contains all Governing Requirements. These are provisions which apply to the function or operation of the NCC itself and explain important concepts or conventions on how to interpret the NCC including specific language and terms.

Part A4 of the NCC explains how documents referenced in the NCC are adopted and applied.

There are three main types of NCC referenced documents:

- Primary referenced documents are documents which are nominated in the NCC and listed in Schedule 2, (formerly Schedule 4 under NCC 2019)
- Secondary referenced document are documents that are not referenced (directly) by the NCC but referenced by a primary referenced document, and
- Other referenced documents which are those referenced by a secondary (or subsequent) referenced document and so on.

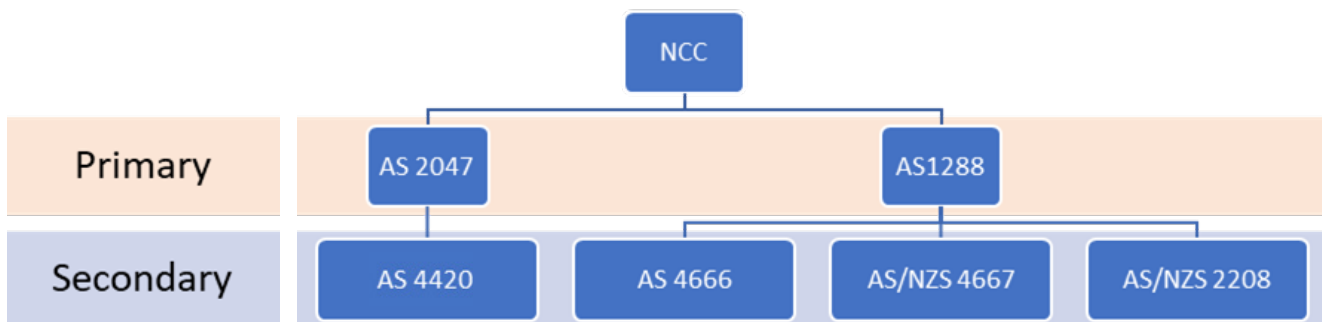

Figure 1: Examples of Primary and Secondary Referenced Documents

Documents referenced by the NCC can be referred to either in full or in part. Some documents are referenced in a particular way or only in a particular context.

Where a conflict or difference exists between a requirement of the NCC and a referenced document, the NCC will over-rule the referenced document.

All primary referenced documents are listed in Schedule 2 of the NCC, including the specific edition or amendment for the referenced document that is adopted under the NCC.



For secondary referenced documents, the edition or amendment that is called on for the purposes of the NCC is the one that existed at the time of publication of the primary referenced document.

This means that a Deemed-to-Satisfy (DTS) Solution using a referenced document must use the version of the referenced document listed in Schedule 2 of the NCC, (or the version of a secondary or other referenced document that existed at the time) even if newer versions are available.

Newer version of a referenced document may be used however, but only as part of a Performance Solution on the basis that users undertaking a performance solution must exercise their own skill and care with respect to their use of this information and ultimately accept responsibility for assessing its relevance and accuracy.

For example:

NCC 2022 reference the 2021 revision of AS 1288 Glass in buildings (referenced as AS 1288:2021), which in-turn references the 1996 revision of AS/NZS 2208 Safety glazing materials in buildings. In both cases these are the current revision of the standards, however in contrast, NCC 2022 references the 2009 revision of AS 1428.1 Design for access and mobility, despite a newer 2021 revision being published.

Key Takouts

- The specific edition or revision of all Australian Standards, and other documents, referenced by the National Construction Code are shown in Schedule 2.
- The version of a secondary referenced document (referenced in a primary referenced document) is the one that existed at the time the primary referenced document was published.
- Newer editions (or amendments of) a referenced document may only be considered for use as part of a Performance Solution.
- Documents referenced by the NCC are only applicable in the context in which they are quoted.
- The NCC overrules in any difference between it and a referenced document.